

SPEEDTRONIC™ Mark VI Turbine Control System

of the overall “system.” Another TMR feature is the ability to distinguish between field sensor faults and internal electronics faults. Diagnostics continuously monitor the 3 sets of input electronics and alarms any discrepancies between them as an internal fault versus a sensor fault. In addition, all three main processors continue to execute the correct “voted” input data. (See Figure 2.)

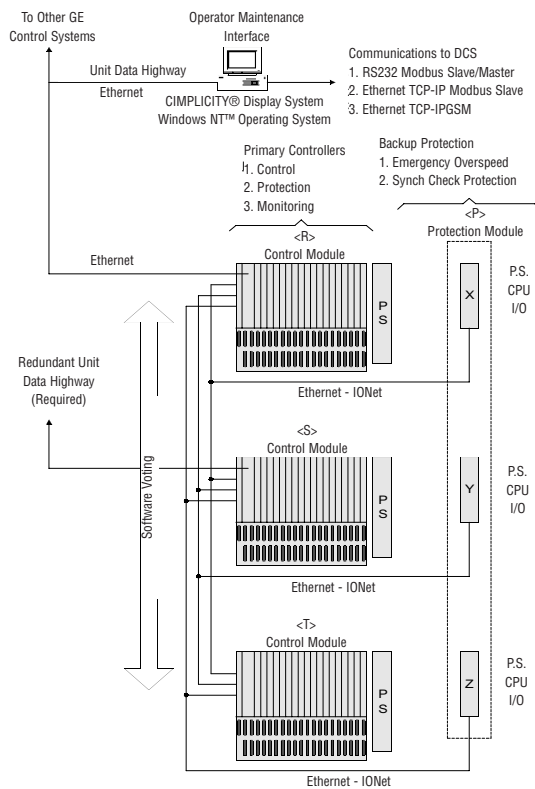

Figure 2. Mark VI TMR control configuration

I/O Interface

There are two types of termination boards. One type has two 24-point, barrier-type terminal blocks that can be unplugged for field maintenance. These are available for Simplex and TMR controls. They can accept two 3.0 mm² (#12AWG) wires with 300 volt insulation. Another type of termination board used on Simplex controls is mounted on a DIN rail and

has one, fixed, box-type terminal block. It can accept one 3.0 mm² (#12AWG) wire or two 2.0 mm² (#14AWG) wires with 300 volt insulation.

I/O devices on the equipment can be mounted up to 300 meters (984 feet) from the termination boards, and the termination boards must be within 15 m (49.2’) from their corresponding I/O cards. Normally, the termination boards are mounted in vertical columns in termination cabinets with pre-assigned cable lengths and routing to minimize exposure to emi-rfi for noise sensitive signals such as speed inputs and servo loops.

General Purpose I/O

Discrete I/O. A VCRC card provides 48 digital inputs and 24 digital outputs. The I/O is divided between 2 Termination Boards for the contact inputs and another 2 for the relay outputs. (See Table 1.)

Analog I/O. A VAIC card provides 20 analog inputs and 4 analog outputs. The I/O is divided between 2 Termination Boards. A VAOC is dedicated to 16 analog outputs and interfaces with 1 barrier-type Termination Board or 2 box-type Termination Boards. (See Table 2.)

Temperature Monitoring. A VTCC card provides interface to 24 thermocouples, and a VRTD card provides interface for 16 RTDs. The input cards interface with 1 barrier-type

TB	Type	I/O	Characteristics
TBCI	Barrier	24 CI	70-145Vdc, optical isolation, 1ms SOE 2.5ma/point except last 3 input are 10ma / point
DTCI	Box	24 CI	18-32Vdc, optical isolation, 1ms SOE 2.5ma/point except last 3 input are 10ma/point
TICI	Barrier	24 CI	70-145Vdc, 200-250Vdc, 90-132Vrms, 190-264Vrms (47-63Hz), optical isolation 1ms SOE, 3ma / point
TRLY	Barrier	12 CO	Plug-in, magnetic relays, dry, form “C” contacts 6 circuits with fused 3.2A, suppressed solenoid outputs Form H1B: diagnostics for coil current Form H1C: diagnostics for contact voltage Voltage Resistive Inductive 24Vdc 3.0A 3.0 amps L/R = 7 ms, no suppr. 3.0 amps L/R = 100 ms, with suppr 125Vdc 0.6A 0.2 amps L/R = 7 ms, no suppr. 0.6 amps L/R = 100 ms, with suppr 120/240Vac 6/3A 2.0 amps pf = 0.4
DRLY	Box	12 CO	Same as TRLY, but no solenoid circuits

Table 1. Discrete I/O

TB	Type	I/O	Characteristics
TBAI	Barrier	10 AI 2 AO	(8) 4-20ma (250 ohms) or +/-5,10Vdc inputs (2) 4-20ma (250 ohms) or +/-1ma (500 ohms) inputs Current limited +24Vdc provided per input (2) +24V, 0.2A current limited power sources (1) 4-20ma output (500 ohms) (1) 4-20ma (500 ohms) or 0-200ma (50 ohms) output
TBAO	Barrier	16 AO	(16) 4-20ma outputs (500 ohms)
DTAI	Box	10 AI 2 AO	(8) 4-20ma (250 ohms) or +/-5,10Vdc inputs (2) 4-20ma (250 ohms) or +/-1ma (500 ohms) inputs Current limited +24Vdc available per input (1) 4-20ma output (500 ohms) (1) 4-20ma (500 ohms) or 0-200ma (50 ohms) output
DTAO	Box	8 AO	(8) 4-20ma outputs (500 ohms)

Table 2. Analog I/O

Termination Board or 2 box-type Termination Boards. Capacity for monitoring 9 additional thermocouples is provided in the Backup Protection Module. (See Table 3.)

TB	Type	I/O	Characteristics
TBTC	Barrier	24 TC	Types: E, J, K, T, grounded or ungrounded H1A fanned (paralleled) inputs, H1B dedicated inputs
DTTC	Box	12 TC	Types: E, J, K, T, grounded or ungrounded
TRTD	Barrier	16 RTD	3 points/RTD, grounded or ungrounded 10 ohm copper, 100/200 ohm platinum, 120 ohm nick H1A fanned (paralleled) inputs, H1B dedicated inputs
DTAI	Box	8 RTD	RTDs, 3 points/RTD, grounded or ungrounded 10 ohm copper, 100/200 ohm platinum, 120 ohm nick

Table 3. Temperature Monitoring

Application Specific I/O

In addition to general purpose I/O, the Mark VI has a large variety of cards that are designed for direct interface to unique sensors and actuators. This reduces or eliminates a substantial amount of interposing instrumentation in many applications. As a result, many potential single-point failures are eliminated in the most critical area for improved running reliability and reduced long-term maintenance. Direct interface to the sensors and actuators also enables the diagnostics to directly interrogate the devices on the equipment for maximum effectiveness. This data is used to analyze device and system performance. A subtle benefit of this design is that spare-parts inventories are

reduced by eliminating peripheral instrumentation. The VTUR card is designed to integrate several of the unique sensor interfaces used in turbine control systems on a single card. In some applications, it works in conjunction with the I/O interface in the Backup Protection Module described below.

Speed (Pulse Rate) Inputs. Four-speed inputs from passive magnetic sensors are monitored by the VTUR card. Another two-speed (pulse rate) inputs can be monitored by the servo card VSVO which can interface with either passive or active speed sensors. Pulse rate inputs on the VSVO are commonly used for flow-divider feedback in servo loops. The frequency range is 2-14k Hz with sufficient sensitivity at 2 Hz to detect zero speed from a 60-toothed wheel. Two additional passive speed sensors can be monitored by “each” of the three sections of the Backup Protection Module used for emergency overspeed protection on turbines that do not have a mechanical overspeed bolt. IONet is used to communicate diagnostic and process data between the Backup Protection Module and the Control Module(s) including cross-tripping capability; however, both modules will initiate system trips independent of the IONet. (See Table 4 and Table 5.)

Synchronizing. The synchronizing system consists of automatic synchronizing, manual synchronizing, and backup synch check protection. Two single-phase PT inputs are provided

TB	Type	I/O	Characteristics
TTUR	Barrier	4 Pulse rate 2 PTs Synch relays 2 SVM	Passive magnetic speed sensors (2-14k Hz) Single phase PTs for synchronizing Auto/Manual synchronizing interface Shaft voltage / current monitor
TRPG* TRPS* TRPL*	Barrier	3 Trip solenoids 8 Flame inputs	(-) side of interface to hydraulic trip solenoids UV flame scanner inputs (Honeywell)
DTUR	Box	4 Pulse Rate	Passive magnetic speed sensors (2-14k Hz)
DRLY DTRT	Box	12 Relays	Form “C” contacts – previously described Transition board between VTUR & DRLY

Table 4. VTUR I/O terminations from Control Module

TB	Type	I/O	Characteristics
TPRO	Barrier	9 Pulse rate 2 PTs 3 Analog inputs 9 TC inputs	Passive magnetic speed sensors (2-14k Hz) Single phase PTs for backup synch check (1) 4-20ma (250 ohm) or +/-5,10Vdc inputs (2) 4-20ma (250 ohm) Thermocouples, grounded or ungrounded
TREG* TRES* TREL*	Barrier	3 Trip solenoids 8 Trip contact in	(+) side of interface to hydraulic trip solenoids 1 E-stop (24Vdc) & 7 Manual trips (125Vdc)

Table 5. VPRO I/O terminations from Backup Protection Module

on the TTUR Termination Board to monitor the generator and line busses via the VTUR card. Turbine speed is matched to the line frequency, and the generator and line voltages are matched prior to giving a command to close the breaker via the TTUR.

An external synch check relay is connected in series with the internal K25P synch permissive relay and the K25 auto synch relay via the TTUR. Feedback of the actual breaker closing time is provided by a 52G/a contact from the generator breaker (not an auxiliary relay) to update the database. An internal K25A synch check relay is provided on the TTUR; however, the backup phase / slip calculation for this relay is performed in the Backup Protection Module or via an external backup synch check relay. Manual synchronizing is available from an operator station on the network or from a synchroscope.

Shaft Voltage and Current Monitor. Voltage can build up across the oil film of bearings until a discharge occurs. Repeated discharge and arcing can cause a pitted and roughened bearing surface that will eventually fail through accelerated mechanical wear. The VTUR / TTUR can continuously monitor the shaft-to-ground voltage and current, and alarm at excessive levels. Test circuits are provided to check the alarm functions and the continuity of wiring to the brush assembly that is mounted between the turbine and the generator.

Flame Detection. The existence of flame either can be calculated from turbine parameters that are already being monitored or from a direct interface to Reuter Stokes or Honeywell-type flame detectors. These detectors monitor the flame in the combustion chamber by detecting UV radiation emitted by the flame. The Reuter Stokes detectors produce a 4-20ma input. For Honeywell flame scanners, the Mark VI supplies the 335Vdc excitation and the VTUR / TRPG monitors the pulses of current being generated. This determines if carbon buildup or other contaminates on the scanner window are causing reduced light detection.

Trip System. On turbines that do not have a mechanical overspeed bolt, the control can issue a trip command either from the main processor card to the VTUR card in the Control Module(s) or from the Backup Protection Module. Hydraulic trip solenoids are wired with the negative side of the 24Vdc/125Vdc circuit connected to the TRPG, which is driven from the VTUR in the Control Module(s) and the positive side connected to the TREG which is driven from the VPRO in each section of the Backup Protection Module. A typical system trip initiated in the Control Module(s) will cause the analog control to drive the servo valve actuators closed, which stops fuel or steam flow and de-energizes (or energizes) the hydraulic trip solenoids from the VTUR and TRPG. If cross-tripping is used or an overspeed condition is detected, then the VTUR/TRPG will trip one side of the solenoids and the VPTRO/TREG will trip the other side of the solenoid(s).

Servo Valve Interface. A VSVO card provides 4 servo channels with selectable current drivers, feedback from LVDTs, LVDRs, or ratio metric LVDTs, and pulse-rate inputs from flow divider feedback used on some liquid fuel systems. In TMR applications, 3 coil servos are commonly